



FIRECO[®]
TELESCOPIC MASTS & FIRE EQUIPMENT

RIMON

ENG

HIGH PERFORMANCE MAST SOLUTIONS

- ELECTROMECHANICAL MECMASTS
- PNEUMATIC MASTS WITH LOCKING SYSTEMS
- PORTABLE FIELD SOLUTIONS





TELESCOPIC MASTS

Fireco is a global leader in the manufacture of telescopic masts made of anodized aluminium tubes and equipped with electromechanical or pneumatic driving systems. These masts will allow you to lift equipment such as antennas, radars, video cameras, and many other devices to heights of up to 40 m.

Today, Fireco offers the largest and most diversified product portfolio on the market. In addition to the great variety of catalogue solutions, customized options which are tailor made according to individual applicational requirements, are also developed on an almost daily basis. Therefore, Fireco masts will perfectly suit virtually every application in various sectors such as defence and marine, surveillance and security, or communications.

The brand Fireco stands for highest quality standards, great reliability and long experience paired with an outstanding versatility and dedication to innovative design.

We take pride in the fact that all our products are 100% made in Italy.

Fireco is present globally with several strategic branches, located in Europe, Asia, the United States, Australia and North Africa. This allows us to be reactive in responding to any type of request, information or intervention, which comes to us from our customers, acquired or potential.

Index.

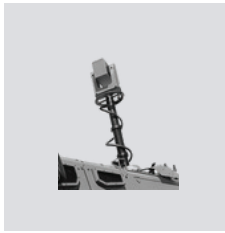

01

INTRODUCTION - 05



04

PORTABLE FIELD
SOLUTIONS - 29



02

ELECTRO MECHANICAL
MASTS - 07



05

ACCESSORIES &
ALTERNATIVE
COATINGS - 33



03

PNEUMATIC MASTS
WITH LOCKING
SYSTEMS - 21



INTRODUCTION



01

FIRECO TELESCOPIC MASTS

Renowned for their reliability and robustness and at the same time easy to operate, Fireco masts are the perfect solution for tough environments. Thanks to the highly diversified range of different models, our masts can suit the most various applications. Our portfolio might be subdivided into three major product lines: high precision electromechanical masts, controlled by PC or remote control - pneumatic masts with mechanical section lockings for long extension times - light masts with tripod for field use. In addition to our catalogue portfolio we also offer customised solutions able to meet even the most demanding requirements.

The range of accessories is highly diversified as well and will allow you to perfectly adapt the masts to the respective mounting sites and operating contexts.

The Electromechanical masts are tested to different MIL-standards and are available with anodising coatings and paint finishes in different colours, e.g. green, sand yellow, black and many more.



RIMON

is the exclusive representative of **FIRECO** in Israel



FIRECO
TELEPHONE MATHS & FIRE EQUIPMENT

02

ELECTROMECHANICAL MASTS

The MecMast offers a unique combination of impressive lifting strength, sturdiness, outstanding reliability and high precision. It is a screw-driven telescopic mast that has been designed to satisfy the specific demands of all kinds of applications in defence, communication and surveillance fields.



THE MECMAST

The MecMast is an excellent technical solution whenever the need to carry out heavy duties is required and precise high accuracy is a critical factor. It also requires low maintenance making it an ideal solution for any application.

The exact position and the desired height can be displayed using various interface options such as PCs or laptops and different remote controls.

KEY FEATURES

- Supports heavy payloads up to 1000 kg
- Extended heights up to 25 m
- Keeps the height and is operative at any intermediate position
- Great variety of "off-the-shelf" and customised solutions
- Wide range of mounting options for installations on vehicles, shelters or on open grounds
- It can be kept extended while vehicle is moving
- Performance proven rugged design guarantees for high resistance to demanding and harsh environment conditions including sand, dust, ice or snow.
- Compliant with MIL-STD-810G, MIL-STD-461F, MIL-STD-1275E, MIL-STD-1686C e MIL-STD-464C
- Durable and reliable with minimum maintenance requirements
- Different communication and control protocols are available (e.g. RS422, RS485, Ethernet, Can bus)

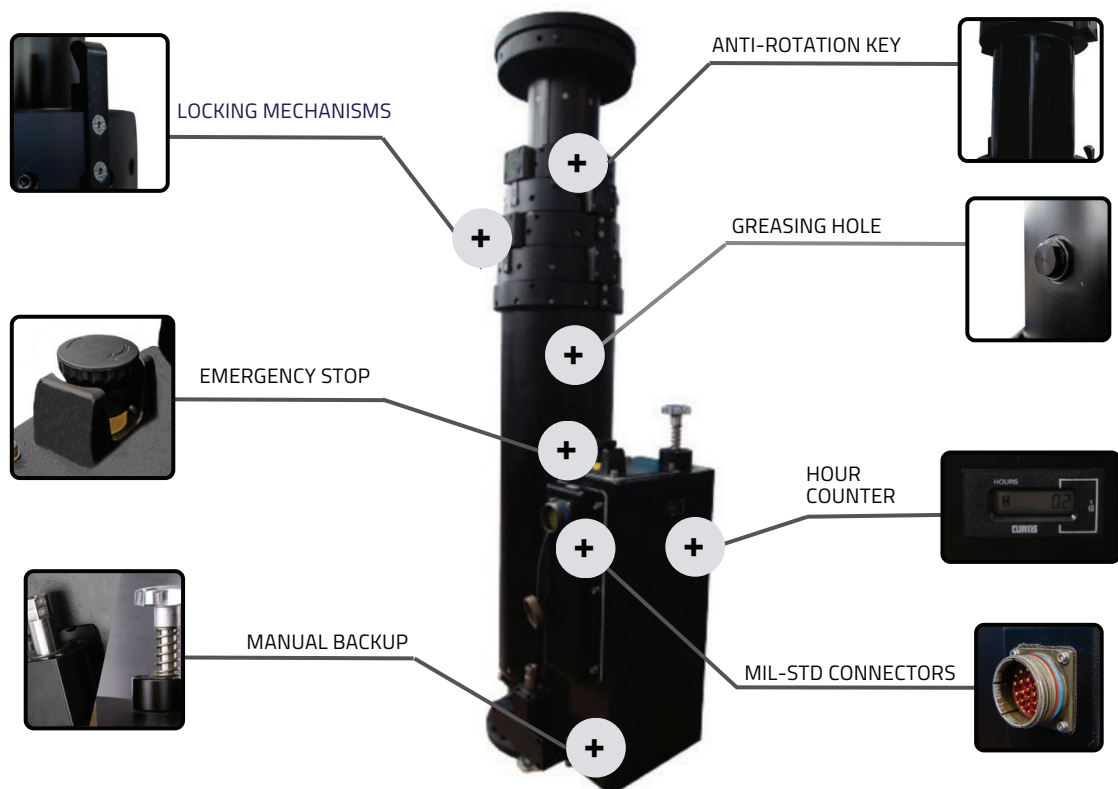

Controlling the MecMast

The MecMast is controlled by a software loaded on a USB drive supplied together with the mast. By installing it, the operator will be able to control the MecMast from a PC or a laptop. The control screen will display the exact extended height, the turning degrees (for MecMast with electrically turn-able base), the actual current consumption, the working cycles and possible warning messages.

The software is available in different languages. In addition, a simple remote control for up/down movements and a complete remote control with LCD display for all functions are also available.

A



B



C



A REMOTE CONTROL WITH LCD DISPLAY

B SIMPLE REMOTE CONTROL

C SOFTWARE PROGRAM FOR LAPTOP/PC USE WITH FULL CONTROL OF THE SYSTEM



MecMast tilting solutions

For the MecMast series Fireco has developed special mounting solutions which allow to move the mast assembly from the horizontal to the vertical position and vice versa. This option renders the mast in the retracted state more compact and reduces the space that is necessary for its installation.

The **MecMast ROOF** is a compact palletised configuration suitable for installations on vehicle platforms such as trailers or trucks. Fireco manufactures a light and a heavy version of this product, both designed to perfectly suit customers' needs.

In addition, the possibility to tilt the mast down to the horizontal position facilitates the operators' access to the mast top and thus makes it easy to mount, dismount or modify.



LIGHT VERSION > PAYLOAD UP TO 100 KG

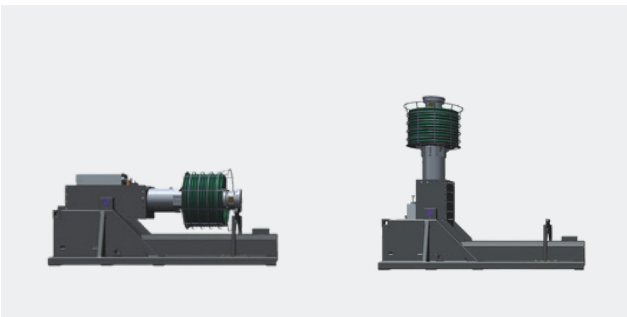

HEAVY VERSION > PAYLOAD UP TO 250 KG





The **90° TILT mechanism** is a unique device that is suitable for mounting the MecMast on the outside of a vehicle or on other structures. This mechanism allows the tilting of the mast from vertical to a position which is more accessible for the users. This permits to easily mount important payloads on the mast top without exposing the operator to risky heights.

A MANUALLY OPERATED WINCH

B ELECTRICALLY OPERATED WINCH

Electrically and manually turnable base

The MecMast is the only electromechanical mast on the market, that is available with a manually or an electrically turnable base. With the electrically turnable base the position can be preset and the degree of rotation can be displayed on the remote control (with LCD) or on your laptop, with a precision of 1°.

Also in case of temporary power loss the system will always show to the operator the correct rotating angle of the mast, even if it has been manually moved during the black-out.



MANUALLY TURNABLE BASE



ELECTRICALLY TURNABLE BASE



Military standards

MIL-STD-461F

CE102 - Conducted emission: Power leads, 10 kHz to 10 MHz

CS101 - Conducted susceptibility: Power leads, 30 Hz to 150 kHz

CS114 - Conducted susceptibility: Bulk cable injection, 10 kHz to 200 MHz

CS115 - Conducted susceptibility: Bulk cable injection, impulse excitation

CS116 - Conducted susceptibility: Damped sinusoidal transients, cables and power leads, 10 kHz to 100 MHz

RS101 - Radiated susceptibility: Magnetic field, 30 Hz to 100 kHz

RS103 - Radiated susceptibility: Electric field, 2 MHz to 18 GHz

MIL-STD-810G

500.5 - Altitude: Sea level up to 15.000 ft (57,18 kPa)

500.5 - Transportation Altitude: Sea level up to 15.000 ft (unpressurized)

501.5 & 502.5 - Operating Temperature Ranges: -44° C to +55° C

501.5 & 502.5 - Storage Temperature Ranges: -44° C to +70° C

506.5 - Rain

508.6 - Fungus

509.5 - Salt Fog

510.5 - Sand and Dust

516.6 - Transit Drop and Crash Hazard

521.3 - Ice and Freezing Rain

MIL-STD-810F

505.4 - Solar Radiation

507.4 - Humidity

514.5 - Vibration

516.5 - Shock

MIL-STD-1275E

Steady State and Transient Voltage

MIL-STD-1686C

Electrostatic discharge

MIL-STD-464C

5.11.3 - Mechanical Interference

Available models

MAIN TUBE Ø127 mm - 4 SECTIONS - END TUBE Ø90 mm

MODEL	DIMENSIONS mm		PAYLOAD	WEIGHT
	EXTENDED	RETRACTED		
MM.0404.SE	4021	1430	90 kg	70 kg
MM.0405.SE	5011	1700	90 kg	74 kg
MM.0406.SE	6011	1980	80 kg	81 kg
MM.0407.SE	7011	2260	80 kg	86 kg
MM.0408.SE	8011	2540	70 kg	91 kg
MM.0409.SE	9011	2820	70 kg	95 kg

MAIN TUBE Ø152 mm - 4 SECTIONS - END TUBE Ø115 mm

MODEL	DIMENSIONS mm		PAYLOAD	WEIGHT
	EXTENDED	RETRACTED		
MM.2404.SE	4021	1430	150 kg	79 kg
MM.2405.SE	5011	1700	150 kg	87 kg
MM.2406.SE	6011	1980	140 kg	93 kg
MM.2407.SE	7011	2260	140 kg	99 kg
MM.2408.SE	8011	2540	130 kg	105 kg
MM.2409.SE	9011	2820	130 kg	111 kg

MAIN TUBE Ø152 mm - 5 SECTIONS - END TUBE Ø102 mm

MODEL	DIMENSIONS mm		PAYLOAD	WEIGHT
	EXTENDED	RETRACTED		
MM.2504.SE	4035	1270	130 kg	80kg
MM.2505.SE	5025	1500	130 kg	86 kg
MM.2506.SE	6045	1720	120 kg	91 kg
MM.2507.SE	7035	1950	120 kg	98 kg
MM.2508.SE	8025	2180	110 kg	104 kg
MM.2509.SE	9045	2400	110 kg	109 kg
MM.2510.SE	10035	2630	100 kg	115 kg

MAIN TUBE Ø152 mm - 6 SECTIONS - END TUBE Ø90 mm

MODEL	DIMENSIONS mm		PAYLOAD	WEIGHT
	EXTENDED	RETRACTED		
MM.2604.SE	4029	1200	110 kg	82 kg
MM.2605.SE	5009	1380	110 kg	87 kg
MM.2606.SE	6049	1570	100 kg	92 kg
MM.2607.SE	7049	1770	100 kg	98 kg
MM.2608.SE	8029	1950	90 kg	104 kg
MM.2609.SE	9009	2130	90 kg	109 kg
MM.2610.SE	10009	2330	80 kg	114 kg
MM.2611.SE	11049	2520	80 kg	119 kg
MM.2612.SE	12029	2700	70 kg	124 kg

DIMENSIONS OF MECMAST WITH MANUALLY TURNABLE BASE

For MecMast Ø 200 - 250 mm please add 204 mm to mast dimensions.
 For MecMast Ø 127 - 152 mm please add 175 mm to mast dimensions.

DIMENSIONS OF MECMAST WITH ELECTRICALLY TURNABLE BASE

For Mast Ø 200 - 250 mm please add 242 mm to mast dimensions.
 For MecMast Ø 127 - 152 mm please add 203 mm to mast dimensions.



Available models

MAIN TUBE Ø200 mm - 5 SECTIONS - END TUBE Ø140 mm

MODEL	DIMENSIONS mm		PAYLOAD	WEIGHT
	EXTENDED	RETRACTED		
MM.3504.SE	4034	1270	210 kg	99 kg
MM.3505.SE	5024	1500	210 kg	108 kg
MM.3506.SE	6014	1730	200 kg	116 kg
MM.3507.SE	7004	1960	200 kg	127 kg
MM.3508.SE	8044	2200	190 kg	136 kg
MM.3509.SE	9014	2410	190 kg	144 kg
MM.3510.SE	1004	2640	180 kg	153 kg

MAIN TUBE Ø200 mm - 6 SECTIONS - END TUBE Ø127 mm

MODEL	DIMENSIONS mm		PAYLOAD	WEIGHT
	EXTENDED	RETRACTED		
MM.3604.SE	4006	1180	190 kg	101 kg
MM.3605.SE	5006	1380	190 kg	109 kg
MM.3606.SE	6046	1570	180 kg	116 kg
MM.3607.SE	7046	1770	180 kg	127 kg
MM.3608.SE	8026	1950	170 kg	134 kg
MM.3609.SE	9026	2150	170 kg	142 kg
MM.3610.SE	10006	2330	160 kg	150 kg
MM.3611.SE	11006	2530	160 kg	158 kg
MM.3612.SE	12046	2720	160 kg	165 kg

MAIN TUBE Ø200 mm - 7 SECTIONS - END TUBE Ø115 mm

MODEL	DIMENSIONS mm		PAYLOAD	WEIGHT
	EXTENDED	RETRACTED		
MM.3704.SE	4028	1130	170 kg	102 kg
MM.3705.SE	5028	1290	170 kg	109 kg
MM.3706.SE	6048	1470	160 kg	117 kg
MM.3707.SE	7048	1630	160 kg	124 kg
MM.3708.SE	8048	1790	150 kg	133 kg
MM.3709.SE	9048	1950	150 kg	140 kg
MM.3710.SE	10068	2130	140 kg	148 kg
MM.3711.SE	11068	2290	140 kg	155 kg
MM.3712.SE	12018	2460	130 kg	163 kg
MM.3713.SE	13018	2620	130 kg	170 kg

MAIN TUBE Ø200 mm - 8 SECTIONS - END TUBE Ø102 mm

MODEL	DIMENSIONS mm		PAYLOAD	WEIGHT
	EXTENDED	RETRACTED		
MM.3805.SE	5000	1250	140 kg	110 kg
MM.3806.SE	6060	1400	140 kg	117 kg
MM.3807.SE	7040	1540	130 kg	124 kg
MM.3808.SE	8020	1680	130 kg	131 kg
MM.3809.SE	9000	1820	120 kg	138 kg
MM.3810.SE	10060	1970	120 kg	145 kg
MM.3811.SE	11040	2110	110 kg	152 kg
MM.3812.SE	12040	2270	110 kg	152 kg
MM.3813.SE	13020	2410	100 kg	166 kg
MM.3814.SE	14000	2550	100 kg	173 kg

Available models

MAIN TUBE Ø200 mm - 9 SECTIONS - END TUBE Ø90 mm

MODEL	DIMENSIONS mm		PAYLOAD	WEIGHT
	EXTENDED	RETRACTED		
MM.3905.SE	5012	1240	120 kg	112 kg
MM.3906.SE	6022	1370	120 kg	118 kg
MM.3907.SE	7012	1480	120 kg	123 kg
MM.3908.SE	8022	1610	110 kg	129 kg
MM.3909.SE	9072	1740	110 kg	137 kg
MM.3910.SE	10042	1870	100 kg	144 kg
MM.3911.SE	11052	2000	100 kg	150 kg
MM.3912.SE	12062	2130	90 kg	156 kg
MM.3913.SE	13072	2260	90 kg	163 kg
MM.3914.SE	14082	2390	80 kg	169 kg
MM.3915.SE	15002	2510	80 kg	175 kg
MM.3916.SE	16012	2640	80 kg	182 kg

MAIN TUBE Ø250 mm - 6 SECTIONS - END TUBE Ø152 mm

MODEL	DIMENSIONS mm		PAYLOAD	WEIGHT
	EXTENDED	RETRACTED		
MM.4604.SE	4026	1200	240 kg	127 kg
MM.4605.SE	5026	1400	240 kg	138 kg
MM.4606.SE	6026	1600	220 kg	149 kg
MM.4607.SE	7026	1800	220 kg	164 kg
MM.4608.SE	8018	1980	200 kg	175 kg
MM.4609.SE	9006	2180	200 kg	187 kg
MM.4610.SE	10046	2370	180 kg	198 kg
MM.4611.SE	11046	2570	180 kg	209 kg
MM.4612.SE	12046	2770	180 kg	222 kg

MAIN TUBE Ø250 mm - 7 SECTIONS - END TUBE Ø140 mm

MODEL	DIMENSIONS mm		PAYLOAD	WEIGHT
	EXTENDED	RETRACTED		
MM.4704.SE	4048	1150	220 kg	128 kg
MM.4705.SE	5048	1310	220 kg	137kg
MM.4706.SE	6068	1490	210 kg	149 kg
MM.4707.SE	7018	1660	210 kg	159 kg
MM.4708.SE	8018	1820	200 kg	172 kg
MM.4709.SE	9018	1980	200 kg	182 kg
MM.4710.SE	10038	2160	190 kg	194 kg
MM.4711.SE	11038	2320	190 kg	204 kg
MM.4712.SE	12058	2500	170 kg	215 kg
MM.4713.SE	13058	2660	170 kg	225 kg

MAIN TUBE Ø250 mm - 8 SECTIONS - END TUBE Ø127 mm

MODEL	DIMENSIONS mm		PAYLOAD	WEIGHT
	EXTENDED	RETRACTED		
MM.4805.SE	5020	1270	200 kg	139 kg
MM.4806.SE	6000	1410	200 kg	148 kg
MM.4807.SE	7060	1560	190 kg	157 kg
MM.4808.SE	8060	1720	190 kg	170 kg
MM.4809.SE	9040	1860	180 kg	180 kg
MM.4810.SE	10020	2000	180 kg	189 kg
MM.4811.SE	11000	2140	170 kg	199 kg
MM.4812.SE	12000	2300	170 kg	209 kg
MM.4813.SE	13060	2450	160 kg	219 kg
MM.4814.SE	14040	2590	160 kg	229 kg



Available models

MAIN TUBE Ø250 mm - 9 SECTIONS - END TUBE Ø115 mm

MODEL	DIMENSIONS mm		PAYLOAD	WEIGHT
	EXTENDED	RETRACTED		
MM.4905.SE	5012	1240	180 kg	138 kg
MM.4906.SE	6022	1370	180 kg	147 kg
MM.4907.SE	7032	1500	180 kg	156 kg
MM.4908.SE	8042	1630	170 kg	165 kg
MM.4909.SE	9072	1780	170 kg	178 kg
MM.4910.SE	10082	1910	160 kg	187 kg
MM.4911.SE	11002	2030	160 kg	195 kg
MM.4912.SE	12012	2160	150 kg	204 kg
MM.4913.SE	13022	2290	150 kg	214 kg
MM.4914.SE	14032	2420	140 kg	223 kg
MM.4915.SE	15062	2570	140 kg	234 kg
MM.4916.SE	16072	2700	130 kg	243 kg

MAIN TUBE Ø250 mm - 10 SECTIONS - END TUBE Ø102 mm

MODEL	DIMENSIONS mm		PAYLOAD	WEIGHT
	EXTENDED	RETRACTED		
MM.5006.SE	6014	1340	160 kg	146 kg
MM.5007.SE	7034	1460	160 kg	155 kg
MM.5008.SE	8054	1580	150 kg	163 kg
MM.5009.SE	9074	1700	150 kg	174 kg
MM.5010.SE	10014	1830	140 kg	184 kg
MM.5011.SE	11034	1950	140 kg	193 kg
MM.5012.SE	12054	2070	130 kg	201 kg
MM.5013.SE	13074	2190	130 kg	210 kg
MM.5014.SE	14044	2305	120 kg	219 kg
MM.5015.SE	15014	2420	120 kg	227 kg
MM.5016.SE	16034	2540	110 kg	236 kg
MM.5017.SE	17054	2660	110 kg	245 kg

MAIN TUBE Ø250 mm - 11 SECTIONS - END TUBE Ø90 mm

MODEL	DIMENSIONS mm		PAYLOAD	WEIGHT
	EXTENDED	RETRACTED		
MM.5106.SE	6046	1340	140 kg	146 kg
MM.5107.SE	7031	1455	140 kg	155 kg
MM.5108.SE	8041	1565	130 kg	164 kg
MM.5109.SE	9051	1675	130 kg	172 kg
MM.5110.SE	10006	1780	120 kg	181 kg
MM.5111.SE	11016	1890	120 kg	189 kg
MM.5112.SE	12026	2000	110 kg	198 kg
MM.5113.SE	13036	2110	110 kg	206 kg
MM.5114.SE	14046	2220	100 kg	215 kg
MM.5115.SE	15056	2330	100 kg	223 kg
MM.5116.SE	16066	2440	90 kg	232 kg
MM.5117.SE	17021	2535	90 kg	240 kg
MM.5118.SE	18031	2655	80 kg	248 kg
MM.5120.SE	20051	2875	80 kg	265 kg

For special dimensions please do not hesitate to contact us..

It is possible to increase the payload by reducing the extension speed slightly.





MecMast accessories

THE LEVELLING SYSTEM is a manually operated device specially designed for vehicle mounted masts. Its purpose is to adjust the mast inclination when the vehicle is on a slope, in order to grant to the equipment mounted on the mast top a horizontal working condition.

It is composed by a lower regulating support bracket, equipped with two manual adjusting handles and an upper holding bracket equipped with an oscillating ring.



Besides the different remote controls, the MecMast can be equipped with various accessories. For example: guying set (including guying collars, ropes, pickets and carrying bag), Nycoil cable conduits, Nycoil baskets,

protection bellows against dust and sand in different colours, ice spacers for using the mast at low temperatures, anti-freeze liquid for preventing the creation of ice layers on the tubes and for melting it, etc



NYCOIL

The Nycoil is made from flexible nylon and is resistant to many chemicals and petroleum based products making its use on vehicles safe and reliable.



PROTECTION BELOW

Protection against dust and sand, available in different colours.



ICE SPACERS

Against compressed ice and snow between the collars.

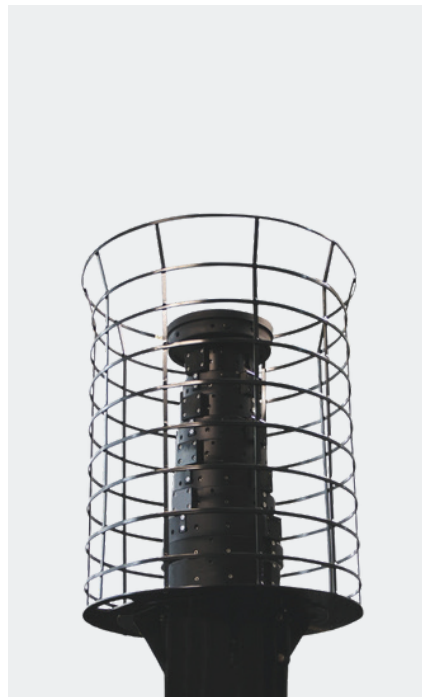

NYCOIL BASKET

Basket for the storing of an external Nycoil cable conduit.

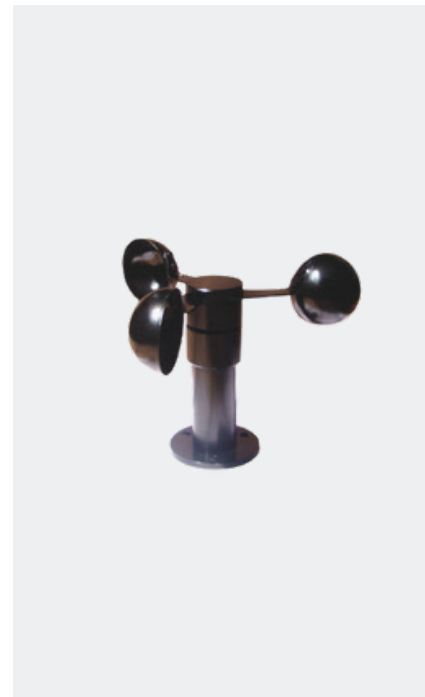

ANEMOMETER

The anemometer is extremely accurate, has a low starting torque, a particularly robust design and is very durable.



ELECTRONIC BOX WITH CONNECTORS

The Mecmast box is available in different versions with a wide range of D38999 connectors.



GLOBETROTTER

中国电信
CHINA TELECOM

330

总质量17000kg

中国电信
CHINA TELECOM



国家应急通信
National Emergency Communications

天翼视讯

RIMON

is the exclusive representative of **FIRECO** in Israel



03

PNEUMATIC MASTS WITH LOCKING SYSTEMS

Whenever important payloads need to be elevated for extended periods, our pneumatic masts with locking systems are the perfect solution. Designed specifically for all kinds of industrial applications that require high lifting capacities to be combined with long-lasting deployment, Fireco's locking masts stand out for their high reliability and are easy to operate at the same time.

The pneumatic masts with locking systems can be kept extended for long periods without internal air pressure. The SUPER STEADY FULL AUTOMATIC, SUPER STEADY SEMI-AUTOMATIC, SUPER STEADY and STEADY masts meet the most demanding requirements of mobile communications, intelligence, surveillance and security systems for defence applications.



SUPER STEADY FULL AUTOMATIC



Super Steady in Full Automatic version is an innovative and patented telescopic mast with a locking system able to operate automatically and thus relieving the operator from the duty to manually unlock/lock each section. The operator can work at a safe distance and decide the height of the mast. The mechanical concept of the Full Automatic Super Steady has been paired to an electropneumatic driving system with integrated safety features, allowing operations via an electronic control box.

Depending on needs or on situations, the mast can work in two modes:

Automatic: for complete extension and retraction

Manual: for extending and retracting the mast manually

The sections can be left in fully extended position without pressurised air inside the mast and the mast can support heavy payloads for long periods.

Backup: in the situation of a sudden power supply failure, the mast can be operated via an emergency backup mode, allowing trained personnel to retract the mast safely.

KEY FEATURES

- *It removes the need to follow some of the most critical safety procedures for operating the mast, allowing faster operations in deployment and reaction*
- *It reduces training costs and improves the installation safety*
- *Maintenance can be performed by skilled personnel with minor and fast efforts as main components are easily accessible*
- *It can support heavy payloads up to 500 kg*



CONTROL BOX

The Full Automatic mast works with a control box that drives a set of electro-pneumatic valves installed in a box nearby the mast. The control box has an intuitive and simple interface, equipped with few clear commands.



ELECTRO-PNEUMATIC BOX

The electro-pneumatic box contains the core elements to drive the air in and out of the mast both during the regular operations and during the manual mode. It houses the delivery valves, all solenoids and the connections to feed both the current and the air to cylinders of the locking keys on the outer tube.

LOCKING SYSTEM

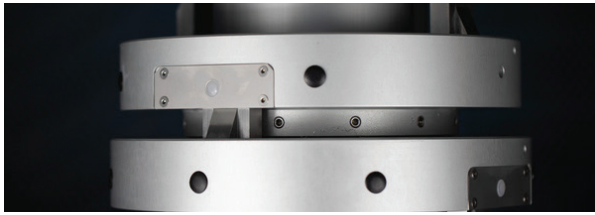

The automatic locking technology is based on a subsystem fully enclosed inside each ring, giving an external surface that is free from possible undesired catch points.

OPTIONAL HEAD LOCKING

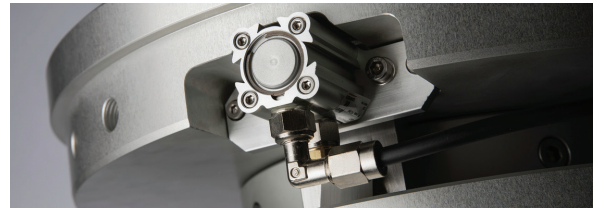

This optional feature is designed to prevent unnecessary movements of the mast head, in the retracted position. When the mast is closed and low pressure is detected, our advanced system engages two actuators to secure the mast head. As pressure rises to optimal levels, the actuators release, allowing the extension process to begin.

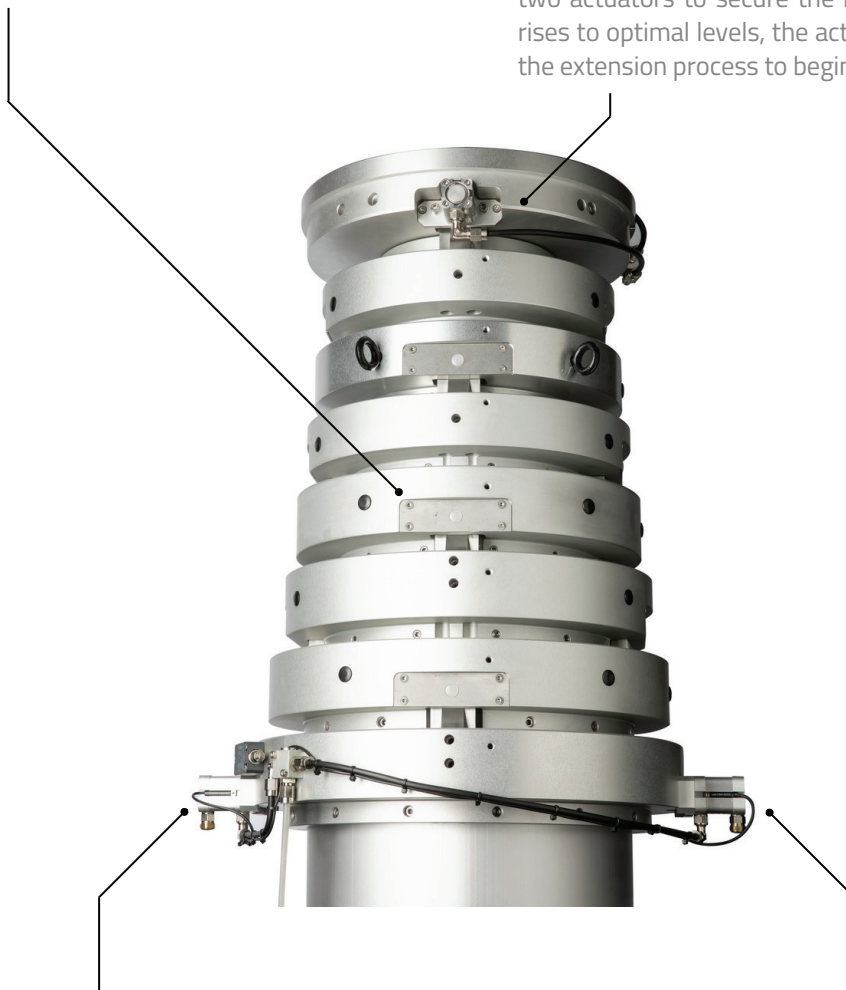

PNEUMATIC FEED SPLITTER MICRO SWITCH



On the first collar, the microswitch signals mast closure/extension to the control box. The pneumatic feed splitter equally distributes air to open the locking actuators upon pressure arrival from the electropneumatic box.

ACTUATORS SAFETY COLLAR



The bottom ring features pneumatic actuators controlled by our advanced system. They automatically lock the mast section when it is extended. During the retraction phase they remain locked, unless safety parameters are met—ensuring



SUPER STEADY SEMI-AUTOMATIC

It is possible to provide the SUPER STEADY masts with a semi-automatic locking system, that allows to unlock both latches of each section by pulling a cord that moves both locking/unlocking levers.

It is not necessary for the operator to manually move the levers back into the locking position, as their movement is automatic; thus the operator can unlock the next stage more quickly.



KEY FEATURES

- *Operating at a safe distance*
- *One single operator*
- *Automatic locking of each section by reaching the correct position*
- *Can be operated from the ground, without access platform*

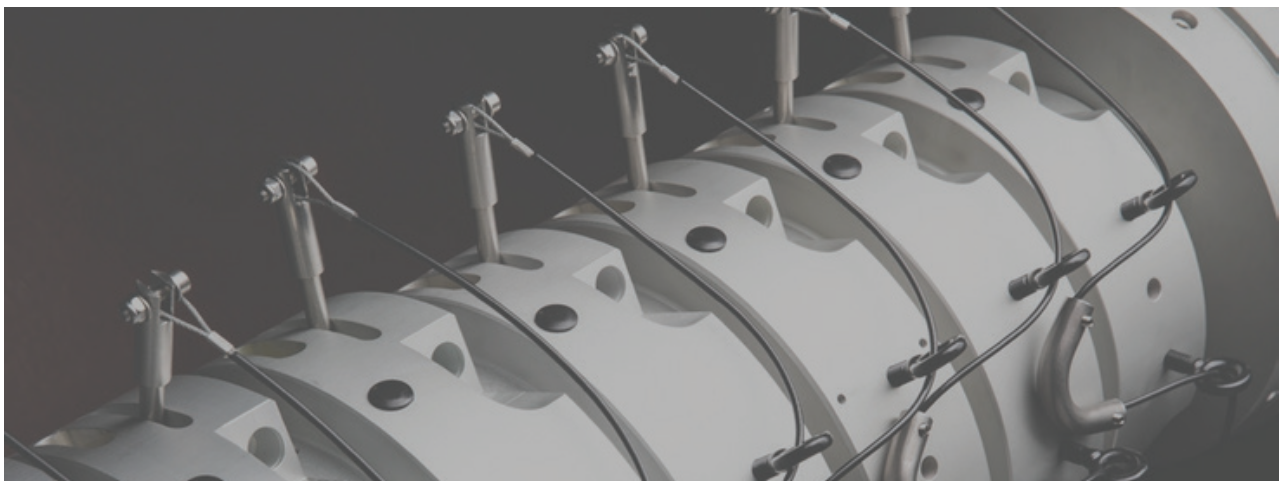



SUPER STEADY

The SUPER STEADY series is equipped with mechanical locking devices. Each section is provided with two lever handles which will insert two bullet latches into the corresponding slots on the mast tube.

- Super Steady masts available with base diameters from 115 mm up to 340 mm
- Solutions with external cables with different types of cable guides or with internal cabling on request
- Permits to mount Dyneema ropes, which grant a better wind speed resistance
- Sturdier lockings
- The Ø 340 mm mast permits to carry particularly huge top loads



PRESSURE GAUGE

On the collar of the main tube there is a pressure gauge that allows to control the internal air pressure on the mast. In order to permit to the user, before retracting the mast, to check and restore the correct internal pressure.

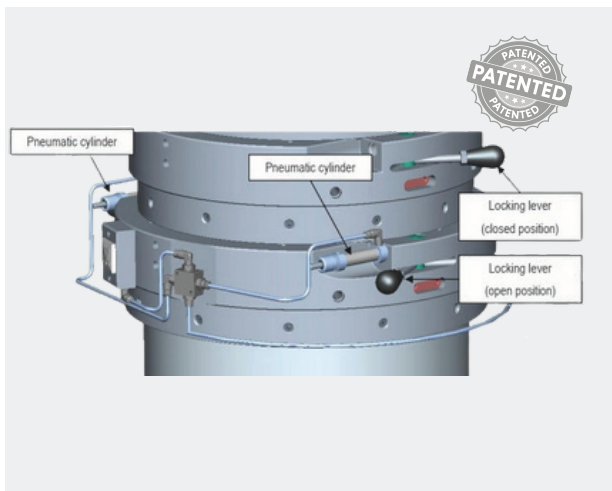

OPTIONAL PNEUMATIC LEVER LOCKING KIT

Its functioning principle is to impede the accidental opening of the locking levers when the air pressure on the mast is not sufficient. In this way one can avoid the risk of a sudden vertical descent of the mast sections.

It is basically composed by two pneumatic cylinders installed in correspondence with the lowest locking ring (coupled with the last mobile tube). When there is no internal air pressure on the mast the cylinders are in an extended position thus impeding the opening of the locking levers of the last mobile tube.

KEY FEATURES FOR SUPER STEADY AND STEADY MASTS

- *Extended heights available up to 40m*
- *Great variety of "off-the-shelf" solutions as well as customised solutions*
- *Wide range of available mounting and guying accessories*
- *Optional special sand scraper rings for dusty and/or harsh environments*
- *Very low maintenance requirements*
- *Customised protection bellows*
- *Customised hole pattern for payload top plate*

STEADY

The STEADY series is equipped with metal bands which embrace each mast section. These bands can be tightened so to keep the sections locked by friction.

- Steady masts available with base diameters from 77 mm up to 250 mm
- Solutions with internal cable or with different types of external cable guides
- Can be locked at every intermediate height





FIRECO
TELESCOPIC MASTS & FIRE EQUIPMENT

RIMON

is the exclusive representative of  **FIRECO** in Israel

04

PORTABLE FIELD SOLUTIONS

Our portable masts, manual or pneumatic, and the wide range of mounting options are essential pieces of equipment for rural operation. Our portable systems are easily and quickly deployable by a single operator, with the mast that can be extended manually, with a hand pump or with a small compressor. Portable masts are usually fitted to a tripod or a 4-legs assembly and can be carried conveniently in protective bags. The masts can be equipped with guying ropes for a better wind resistance.



PORTABLE SOLUTIONS

Here some examples of our manual telescopic masts, equipped with manual lockings on each section.

This is a small extract of our complete range. Please contact us if you would like to receive more information.

LIGHTWEIGHT MASTS WITH INTERNAL CABLE

MAST	MODEL	DIMENSIONS mm		DIAMETER mm	SECTIONS	PAYLOAD	WEIGHT
		EXTENDED	RETRACTED				
ENTRY	CN.5211.P	2004	1200	66	2	23 kg	4,5 kg
	CN.5304.P	3963	1135		3	20 kg	7 kg
SUPER ENTRY	CO.5436.P	3499	1240	80	4	26 kg	6 kg
	CO.5515.P	6000	1714		6	20 kg	11,5 kg

LIGHTWEIGHT MASTS WITHOUT INTERNAL CABLE

MAST	MODEL	DIMENSIONS mm		DIAMETER	SECTIONS	PAYLOAD	WEIGHT
		EXTENDED	RETRACTED				
STAR	CA.5221.P	1930	1120	66	2	23 kg	4,5 kg
	CA.5503.P	4940	1370		5	12 kg	8 kg
PRIMO	CP.5411.P	2963	1070	66	4	16 kg	6 kg
	CP.5608.P	9080	1960		6	6 kg	11,5 kg
SUPER PRIMO	CO.5426.P	4983	1650	80	4	24 kg	10,5 kg
	CO.5806.P	5799	1200		8	9 kg	18,9 kg
MAXI PRIMO	CM.5701.P	7476	1575	101	7	22 kg	19,6 kg
	CM.5106.P	12455	1810		11	6 kg	25,6 kg



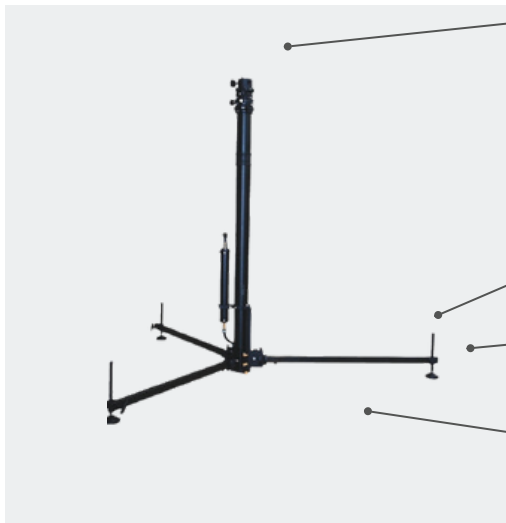

COMPACT CLOSED POSITION,
EASY TO BE TRANSPORTED

FOOT STAFF AVAILABLE WITH
ROPE CONNECTION

STABILIZING FEET AVAILABLE Ø 80,
Ø 150 AND Ø 250 mm

LEGS AVAILABLE WITH LENGTHS
850 – 1100 – 1500 – 2000 mm

TRIPOD



REINFORCEMENT BARS

CLIMBING STEPS

AVAILABLE: LOWER PLATE WITH OR WITHOUT
SPHERICAL BASE FOR MAST

4 LEGS ASSEMBLY



TRANSPORTABLE SEPARATELY
FROM THE MAST

TELESCOPIC LEGS - ADAPTABLE
TO THE GROUND

TRIPOD



RIMON is the exclusive representative of **FIRECO** in Israel



05

ACCESSORIES & ALTERNATIVE COATINGS

Many accessories and add-ons round off our product portfolio and give you the possibility to perfectly adapt every single mast model to the particular requirements of your specific application. In addition to that, for all our masts we offer a great variety of anodised coatings and painting finishes in different colours.



ACCESSORIES



DIFFERENT CARRYING BAGS
ARE AVAILABLE IN BLACK
OR GREEN COLOUR

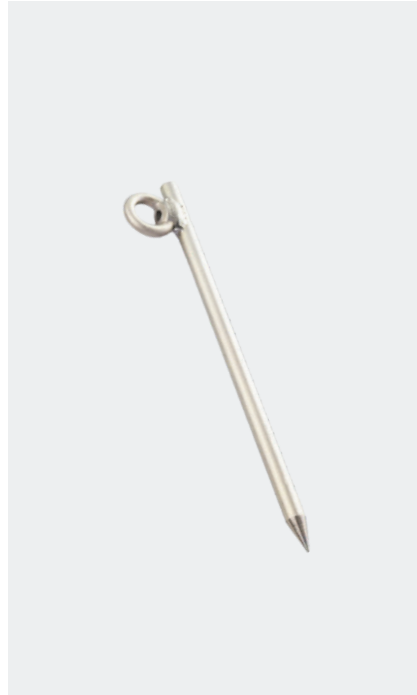

PICKETS FOR GUY ROPE ANCHORING
TO THE GROUND

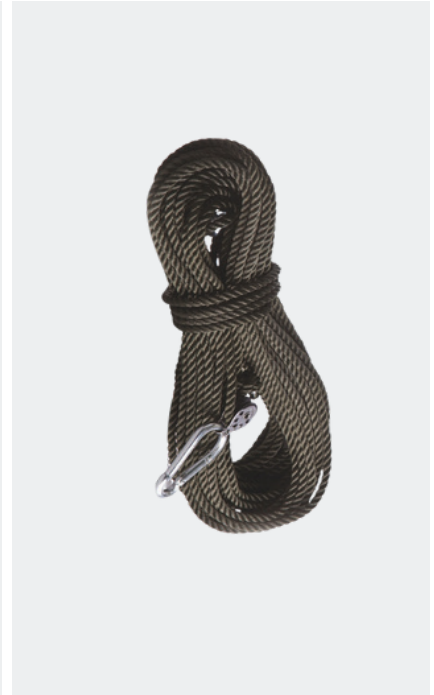

GUYING ROPES OF DIFFERENT LENGTHS
ALSO AVAILABLE IN DYNEEMA



SAND SCRAPER RINGS

ALTERNATIVE COATING

THIS TREATMENT GUARANTEES FOR:

- improved corrosion resistance
- increased surface hardness
- increased wear and abrasion resistance
- moderate heat insulation

Hard anodization is also available as well as a wide variety of different anodization and painting colours, some examples of which you will find below

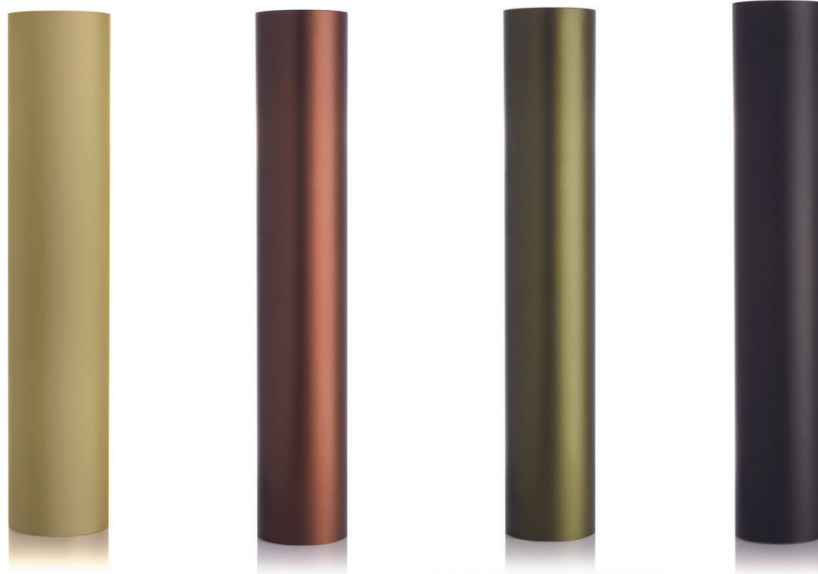

For enquiries, requests or questions of any kind, please don't hesitate to contact us. You will find our contact details on the back of this brochure.



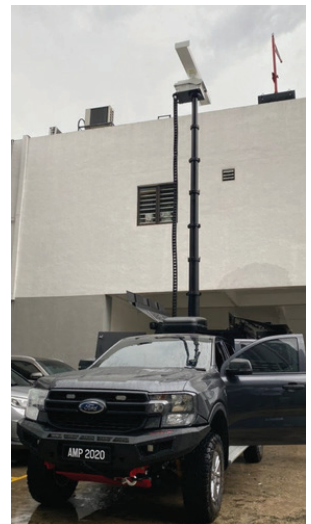





Credits

Copyright 2024- FIRECO - All rights reserved

ITALIAN HEADQUARTERS

Fireco S.r.l.

Via E.Fermi, 56
25064 GUSSAGO (BS) - ITALY
Tel.:+39 030 3733916
Fax:+39 030 3733762
info@fireco.eu
www.fireco.eu

FIRECO.EU



BELGIUM

Fireco Systems N.V.

Diestersteenweg, 142
3510 KERMT (HASSELT) - BELGIUM
Tel.:+32 11851602
Fax:+32 11851604
info@fireco.be
www.fireco.be

FRANCE

Euromast S.a.r.l.

101 Rue Louis Armand
73420 MERY - FRANCE
Tel.:+33 479349215
Fax:+33 479349216
fireco@euromast.fr
www.euromast.fr

SPAIN

Hispamast S.L.

C/Estaño, 30
28510 CAMPO REAL (MADRID) - SPAIN
Tel.:+34 918733733
Fax:+34 918765141
info@hispamast.com
www.hispamast.com

USA

Fireco US

1740 N Gateway Blvd
FRESNO, CA 93727 - USA
Tel.:+1 559 353-2823
Fax: +1 559 255-7012
info@firecousa.com
www.firecousa.com

MALAYSIA

Fireco Asia Sdn Bhd

9, Jalan TP 3/2, Taman Perindustrian UEP
47620 SUBANG JAYA - MALAYSIA
Tel.:+603 8011 2300
Fax:+603 8081 2367
gc@fireco-asia.com
www.fireco-asia.com

AUSTRALIA

EVTA Group PTY LTD

12 Meek Street,
NEW GISBORNE, VICTORIA, 3438 - AUSTRALIA
Tel.:+61 354207444
Fax:+61 354207834
info@evtagroup.com.au
www.evtagroup.com.au

MOROCCO

Euro-Fireco

Résidence les jardins Al Noamane
Rue Izdihar, Bouskoura,
Casablanca - MOROCCO
Tel.:+212 5220-66343
info@euro-fireco.com
www.euro-fireco.com

FIRECO.EU

RIMONis the exclusive representative of  **FIRECO** in IsraelTELECOMUNICAZIONE E INNESTAMENTO